



EcoFlow™ C1

The EcoFlow™ C1 mobile filter unit (MFU) is specially developed and built for the treatment of air and gases. The filtration unit is a combined transport vessel and adsorption system delivered, prefilled with selected adsorbent media, to ensure cost effective purification results. The EcoFlow™ C1 can be used as a single filter, in parallel or in series depending on the needs of the customer's application. The mobile filter unit EcoFlow™ C1 is taken offline, once the adsorbent is spent or the treatment objective is reached, the entire unit is removed from site and if required, replaced with another filter. This eliminates the need for onsite spent carbon handling and minimises the transport cost.

Total service package

The Jacobi mobile filter units EcoFlow™ are supplied as a complete service package having several advantages:

Easy solution

- Combined filter and transport unit
- Rapid and easy site installation
- Quick couplings
- No on-site carbon handling

Availability

- Ex-stock delivery available
- For temporary need in case of toll manufacturing or emergency
- Total service package can be offered
- Auxiliary equipment (e.g. fans and skids) available

Cost effective

- No investment cost
- No maintenance cost
- Low operating cost (mobile filters often need less energy compared to other solutions)



Thermal reactivation of spent carbon

Activated carbon is used in a wide range of applications. Adsorbents generally have a limited lifetime and need to be managed once they are saturated or the treatment objective is reached. Jacobi Services offers several disposal or recycling services in different processing facilities. Our philosophy is always to reactivate the spent carbon, but in the exceptional case where this is not possible, Jacobi Services provides alternative solutions.



Technical data

Description	Value
Flow rate, range (m ³ /h)	150-1 500
Temperature, Max. (°C) ¹	80
Pressure, Max. (barg)	0.3
Vacuum, Max. (barg) ²	-0.1
Media volume, Max. (m ³)	1
Volume – Container (m ³)	1.1
Materials of construction – Container	AISI 304
Materials of construction – Pipework	N/A
Coating – Container	N/A
Gaskets ³	EPDM
Fluid inlet/outlet	DN 150
Drain valve	DN 20
Inlet/outlet sampling	N/A
Inertisation	DN 15
Clearance height, Min. (m)	2.5
Drained weight, Max. (MT)	1.5
Operating weight, Max. (MT)	2

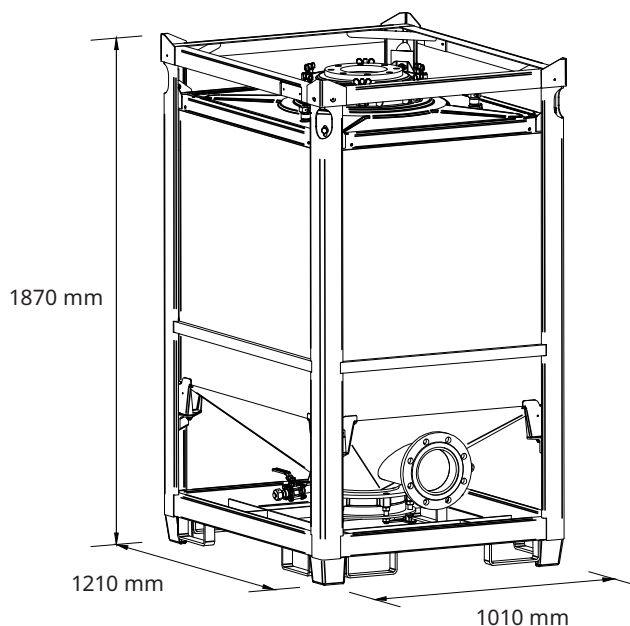

- 1 The mobile filter unit should not be operated above the maximum temperature. If the operating temperature is higher than 40 °C then the necessary safety precautions should be taken.
- 2 The MFU should not be operated below the indicated vacuum.
- 3 Other gaskets can be made available.

Safety information

Jacobi Services customers using mobile filters rarely come in direct contact with the media used in the process. Nevertheless, it is advised to consult the extended safety data sheets (eSDS) for the particular activated carbon grade in use.

Wet activated carbon depletes oxygen from air and, therefore, dangerously low levels of oxygen may be encountered. Whenever workers enter a vessel containing activated carbon, the oxygen content should be determined and work procedures for potentially low oxygen content areas should be followed.

In exceptional conditions a hotspot can be produced by heat of adsorption and exothermic reaction of the activated carbon bed with certain substances. The user should undertake a risk assessment and implement the necessary precautions to comply with the local safety regulations for the unlikely event of a hotspot or bed fire, if deemed necessary.

Pressure drop

The pressure drop of a mobile filter depends on the filter type, product type and operating conditions and the properties of the gas. Pressure drop over a mobile filter system can be predicted by using the standard Jacobi pressure drop curves. Dust and particulate matter in the process stream can have an impact on the pressure drop.



Jacobi Corporate Headquarters
Slöjdaregatan 1
SE-39353 Kalmar | Sweden
Tel: +46 480 41 7550 | Fax: +46 480 41 7559
info@jacobi.net | www.jacobi.net



JACOBI SERVICES IS A PROUD
MEMBER OF THE OSAKA GAS
CHEMICALS GROUP

FOR MORE INFORMATION OR TO CONTACT JACOBI VISIT: WWW.JACOBI.NET

NOTICE Due to the progressive nature of the Jacobi Carbons Group and the continually improving design and performance of our products, we reserve the right to change product specifications without prior notification. The information contained in this datasheet is intended to assist a customer in the evaluation and selection of products supplied by Jacobi Carbons. The customer is responsible for determining whether products and the information contained in this document are appropriate for customer's use. Jacobi Carbons assumes no obligation or liability for the usage of the information in this datasheet, no guarantees or warranties, expressed or implied, are provided. Jacobi Carbons disclaims responsibility and the user must accept full responsibility for performance of systems based on this data.

© Copyright: Jacobi, Jacobi Carbons, PICA and the Jacobi and PICA logos are registered trademarks and AquaSorb, EcoSorb, ColorSorb, DioxSorb, AddSorb, ReSorb, PICA-TIF, PICA-PURE, PICA-TOX, PICA-CARB, PICA-GOLD, PICA-RESP, PICA-HYDRO and PICA-CLEAN are trademarks of Jacobi Carbons, all of which may or may not be used in certain jurisdictions.

JACOBI-TDS-ECOFLOW-C1-A4-ENG-G0221



EcoFlow™ C2

The EcoFlow™ C2 mobile filter unit (MFU) is specially developed and built for the treatment of air and gases. The filtration unit is a combined transport vessel and adsorption system delivered, prefilled with selected adsorbent media, to ensure cost effective purification results. The EcoFlow™ C2 can be used as a single filter, in parallel or in series depending on the needs of the customer's application. The mobile filter unit EcoFlow™ C2 is taken offline, once the adsorbent is spent or the treatment objective is reached, the entire unit is removed from site and if required, replaced with another filter. This eliminates the need for onsite spent carbon handling and minimises the transport cost.

Total service package

The Jacobi mobile filter units EcoFlow™ are supplied as a complete service package having several advantages:

Easy solution

- Combined filter and transport unit
- Rapid and easy site installation
- Quick couplings
- No on-site carbon handling

Availability

- Ex-stock delivery available
- For temporary need in case of toll manufacturing or emergency
- Total service package can be offered
- Auxiliary equipment (e.g. fans and skids) available

Cost effective

- No investment cost
- No maintenance cost
- Low operating cost (mobile filters often need less energy compared to other solutions)



Thermal reactivation of spent carbon

Activated carbon is used in a wide range of applications. Adsorbents generally have a limited lifetime and need to be managed once they are saturated or the treatment objective is reached. Jacobi Services offers several disposal or recycling services in different processing facilities. Our philosophy is always to reactivate the spent carbon, but in the exceptional case where this is not possible, Jacobi Services provides alternative solutions.



Technical data

Description	Value
Flow rate, range (m ³ /h)	200–2 000
Temperature, Max. (°C) ¹	80
Pressure, Max. (barg)	0.3
Vacuum, Max. (barg) ²	-0.1
Media volume, Max. (m ³)	2
Volume – Container (m ³)	2.2
Materials of construction – Container	AISI 304
Materials of construction – Pipework	N/A
Coating – Container	N/A
Gaskets ³	EPDM
Fluid inlet/outlet	DN 150
Drain valve	DN 20
Inlet/outlet sampling	N/A
Inertisation	DN 15
Clearance height, Min. (m)	2.5
Drained weight, Max. (MT)	2.5
Operating weight, Max. (MT)	3.5

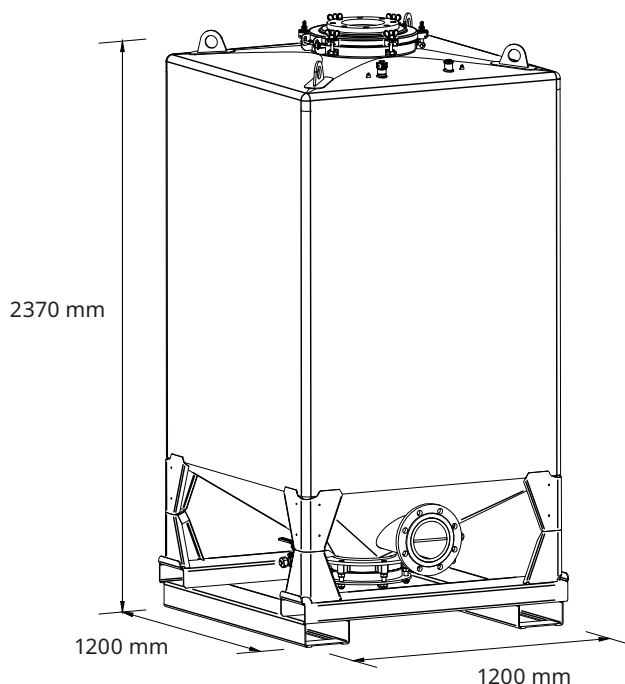

- 1 The mobile filter unit should not be operated above the maximum temperature. If the operating temperature is higher than 40 °C then the necessary safety precautions should be taken.
- 2 The MFU should not be operated below the indicated vacuum.
- 3 Other gaskets can be made available.

Safety information

Jacobi Services customers using mobile filters rarely come in direct contact with the media used in the process. Nevertheless, it is advised to consult the extended safety data sheets (eSDS) for the particular activated carbon grade in use.

Wet activated carbon depletes oxygen from air and, therefore, dangerously low levels of oxygen may be encountered. Whenever workers enter a vessel containing activated carbon, the oxygen content should be determined and work procedures for potentially low oxygen content areas should be followed.

In exceptional conditions a hotspot can be produced by heat of adsorption and exothermic reaction of the activated carbon bed with certain substances. The user should undertake a risk assessment and implement the necessary precautions to comply with the local safety regulations for the unlikely event of a hotspot or bed fire, if deemed necessary.

Pressure drop

The pressure drop of a mobile filter depends on the filter type, product type and operating conditions and the properties of the gas. Pressure drop over a mobile filter system can be predicted by using the standard Jacobi pressure drop curves. Dust and particulate matter in the process stream can have an impact on the pressure drop.



Jacobi Corporate Headquarters
Slöjdaregatan 1
SE-39353 Kalmar | Sweden
Tel: +46 480 41 7550 | Fax: +46 480 41 7559
info@jacobi.net | www.jacobi.net

FOR MORE INFORMATION OR TO CONTACT JACOBI VISIT: WWW.JACOBI.NET

NOTICE Due to the progressive nature of the Jacobi Carbons Group and the continually improving design and performance of our products, we reserve the right to change product specifications without prior notification. The information contained in this datasheet is intended to assist a customer in the evaluation and selection of products supplied by Jacobi Carbons. The customer is responsible for determining whether products and the information contained in this document are appropriate for customer's use. Jacobi Carbons assumes no obligation or liability for the usage of the information in this datasheet, no guarantees or warranties, expressed or implied, are provided. Jacobi Carbons disclaims responsibility and the user must accept full responsibility for performance of systems based on this data.

© Copyright: Jacobi, Jacobi Carbons, PICA and the Jacobi and PICA logos are registered trademarks and AquaSorb, EcoSorb, ColorSorb, DioxSorb, AddSorb, ReSorb, PICTACTIF, PICAPURE, PICATOX, PICACARB, PICAGOLD, PICARESP, PICAHYDRO and PICACLEAN are trademarks of Jacobi Carbons, all of which may or may not be used in certain jurisdictions.



JACOBI SERVICES IS A PROUD
MEMBER OF THE OSAKA GAS
CHEMICALS GROUP